

9998 OLD PLACERVILLE ROAD
 Sacramento, CA. 95827
 Phone: (916) 363-2681; Fax: (916) 363-4537
 www.claytonhomes.com www.karstenhomes.com

DRAWING
 TITLE:

SALES FLOOR PLAN (ZERH)

DRAWING FILE INFORMATION:

STANDARD AS OF REVISION DATE

PRODUCT: CORONADO SERIES	DESIRP.: 24523B	MODEL NO.: COR24523B
	SQUARE FT.: 1158/1254	DATE: 10/04/19
DRAWN BY:	SHEET:	REVISED: 05-17-23

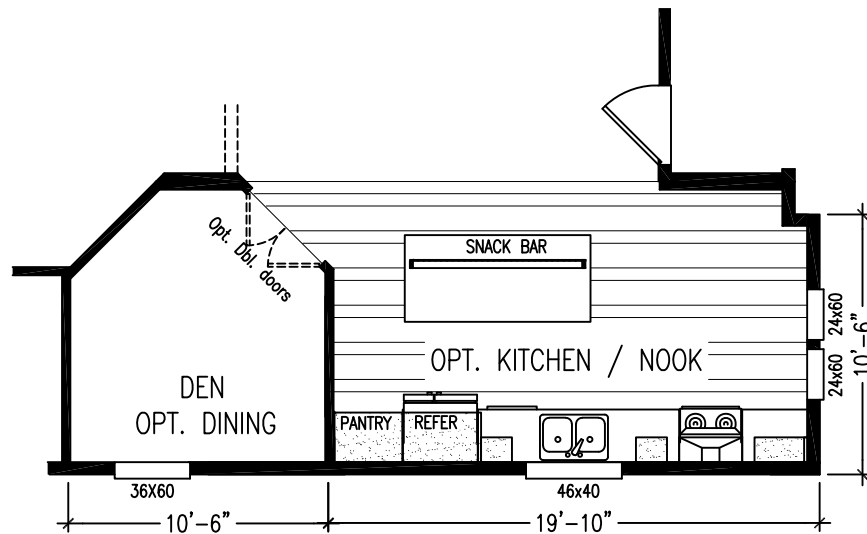

9998 OLD PLACERVILLE ROAD
 Sacramento, CA. 95827
 Phone: (916) 363-2681; Fax: (916) 363-4537
 www.claytonhomes.com www.karstenhomes.com

DRAWING
 TITLE:

OPT. SALES FLOOR PLAN

DRAWING FILE INFORMATION:

STANDARD AS OF REVISION DATE

PRODUCT: CORONADO SERIES	DESRIP.: 24523B	MODEL NO.: COR24523B
	SQUARE FT.: 1158	DATE: 10/04/19
DRAWN BY:	SHEET:	REVISED: 05-17-23

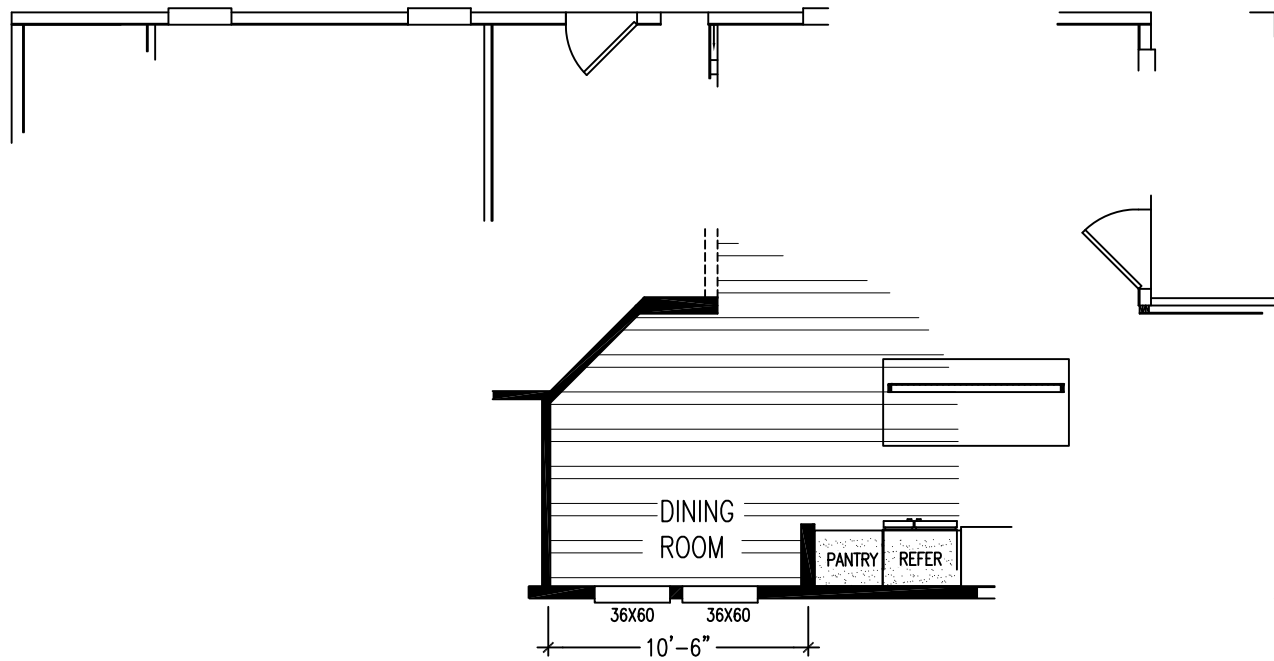

9998 OLD PLACERVILLE ROAD
 Sacramento, CA. 95827
 Phone: (916) 363-2681; Fax: (916) 363-4537
 www.claytonhomes.com www.karstenhomes.com

DRAWING
 TITLE:

OPT. SALES FLOOR PLAN

DRAWING FILE INFORMATION:

STANDARD AS OF REVISION DATE

PRODUCT: CORONADO SERIES	DESRIP.: 24523B	MODEL NO.: COR24523B
	SQUARE FT.: 1158	DATE: 10/04/19
DRAWN BY:	SHEET: 1-C	REVISED: 05-17-23

CLAYTON HOME BUILDING GROUP CORONADO

Model Number	24523B	Drawing Number	COR24523B	STD
--------------	--------	----------------	-----------	-----

BOX SIZE: 23.67 ft. x 52 ft.

AVG. SIDEWALL HEIGHT = 9 FEET

PERCENTAGE OF CEILING THAT IS VAULTED = 0%

12 INCH DIAMETER XOVER DUCT AREA = 78.5 SQ.FT. MAX. WITH R-8 INSULATION

	FLOOR	WALL	FLAT ROOF
INSULATION VALUES	R-21 OR / R-22	R-19	R-38
DAPIA PAGE	THP-202	THP-556	THP-1211
U VALUE (BTUH/SQ.FT.-F)	0.0447	0.0617	0.0290

DOUBLE WIDE ONLY

Max Glazing

R-11	46.5
R-13	96.9
R-15	143.5
R-11 + R3	149.1
R-13 + R3	186.7
R-15 + R3	212.2

Max Glass (sq ft)	
Th. Zone 1	483.6
Th. Zone 2	221.7
Th. Zone 3	43.0

Max Uo - New Energy Star v3.0		
Category	Single	Multi
1	0.076	0.070
2	0.065	0.063
3	0.056	0.053

		Area	U Value	UA
Doors:	Front	22.00	0.300	6.60
	Rear	20.00	0.300	6.00
	Other Door	0.00	0.300	0.00
	Other Door	0.00	0.330	0.00
	OSB	0.00	0.000	0.00
Window Glass Area:	Std	171.00	0.290	49.59
	Opt	0.00	0.300	0.00
Net:	Floor	1230.67	0.045	55.01
	Wall	1149.00	0.062	70.89
	Ceiling	1230.67	0.0290	35.69
Th. Zone 1:	Ext. Duct	78.50	0.242	18.98
Th. Zone 2:	Ext. Duct	78.50	0.223	17.48
Th. Zone 3:	Ext. Duct	78.50	0.206	16.14
Overhead TZ 1:	Supply	0.00	0.00	0.00
Overhead TZ 2:	Supply	0.00	0.00	0.00
Overhead TZ 3:	Supply	0.00	0.00	0.00

		Outdoor Design Temp (F)	UA	Uo	Heatloss BTUH/F
Thermal Zone 1	11	242.77	0.0634	348.70	
Thermal Zone 2	0	241.26	0.0630	347.20	
Thermal Zone 3	-14	239.92	0.0626	345.90	

Design Temperatures

Furnace Heating Temp (F)	Economy Outdoor Temp (F)	
-28	2	10kW
-47	-12	12kW
-77	-33	15kW
-45	-10	40k Gas
-102	-50	60k Gas
-159	-91	80k Gas

Thermal Zone	U-Value	Thermal Zone	U-Value	Thermal Zone	U-Value
1	0.116	2	0.096	3	0.079
1-EHP-S	0.080	2-EHP-S	0.080	3-EHP-S	0.079
1-GAS-S	0.080	2-GAS-S	0.080	3-GAS-S	0.071
1-ENV-S	0.076	2-ENV-S	0.067	3-ENV-S	0.059
1-EHP-M	0.074	2-EHP-M	0.074	3-EHP-M	0.074
1-GAS-M	0.074	2-GAS-M	0.074	3-GAS-M	0.065
1-ENV-M	0.071	2-ENV-M	0.064	3-ENV-M	0.056

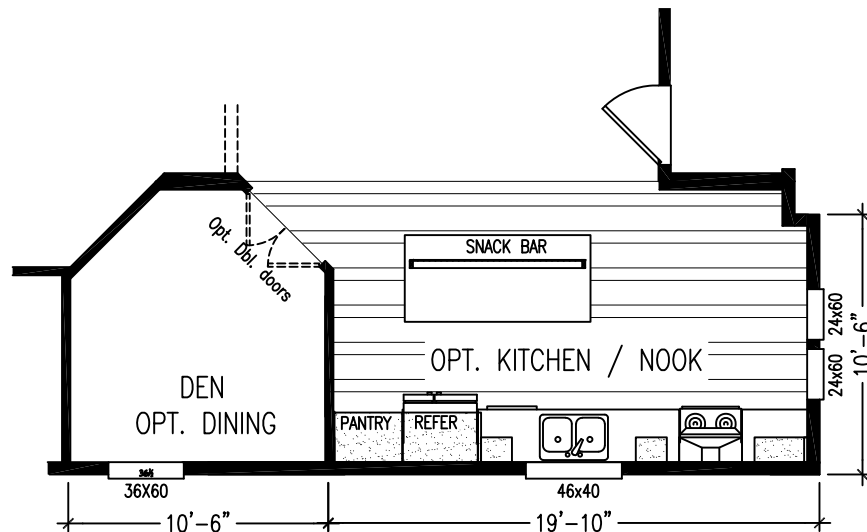

9998 OLD PLACERVILLE ROAD
 Sacramento, CA. 95827
 Phone: (916) 363-2681; Fax: (916) 363-4537
 www.claytonhomes.com www.karstenhomes.com

DRAWING
 TITLE:

OPT. SALES FLOOR PLAN

DRAWING FILE INFORMATION:

STANDARD AS OF REVISION DATE

PRODUCT: CORONADO SERIES	DESRIP.: 24523B	MODEL NO.: COR24523B
	SQUARE FT.: 1160/1254	DATE: 10/04/19
DRAWN BY:	SHEET:	REVISED: 06-30-20

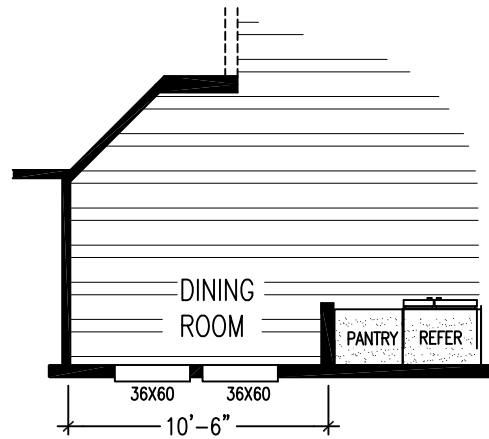

9998 OLD PLACERVILLE ROAD
 Sacramento, CA. 95827
 Phone: (916) 363-2681; Fax: (916) 363-4537
 www.claytonhomes.com www.karstenhomes.com

DRAWING
 TITLE:

OPT. SALES FLOOR PLAN

DRAWING FILE INFORMATION:

STANDARD AS OF REVISION DATE

PRODUCT: CORONADO SERIES	DESRIP.: 24523B	MODEL NO.: COR24523B
	SQUARE FT.: 1160/1254	DATE: 10/04/19
DRAWN BY:	SHEET: 1-C	REVISED: 06-30-20

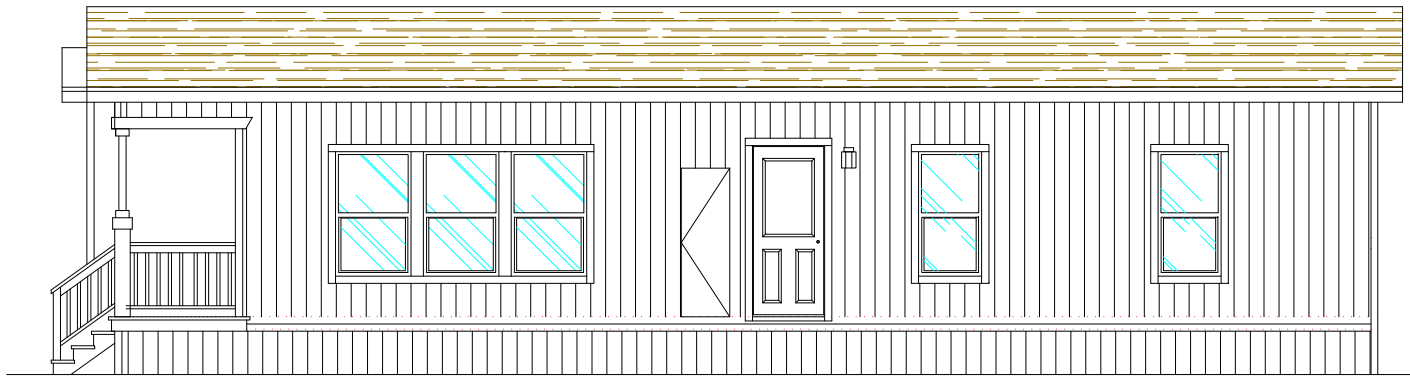

SIDEWALL ELEVATION - RIGHT

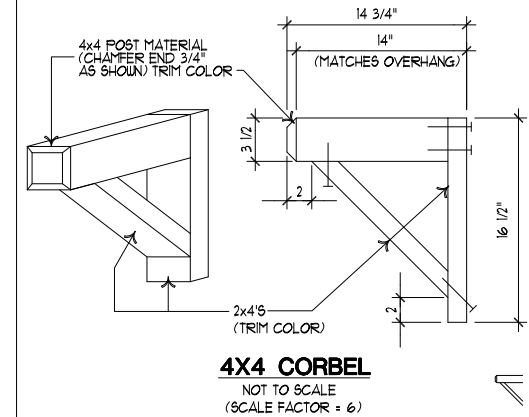

NOTES:

1. 9' SIDEWALL WITH FLAT CEILING
2. ROOF PITCH 3:12

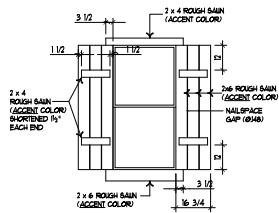

CORONADO CRAFTSMAN SHUTTER DETAIL

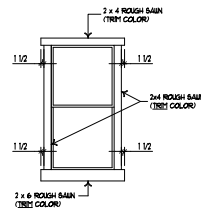

CORONADO CRAFTSMAN WINDOW TRIM DETAIL

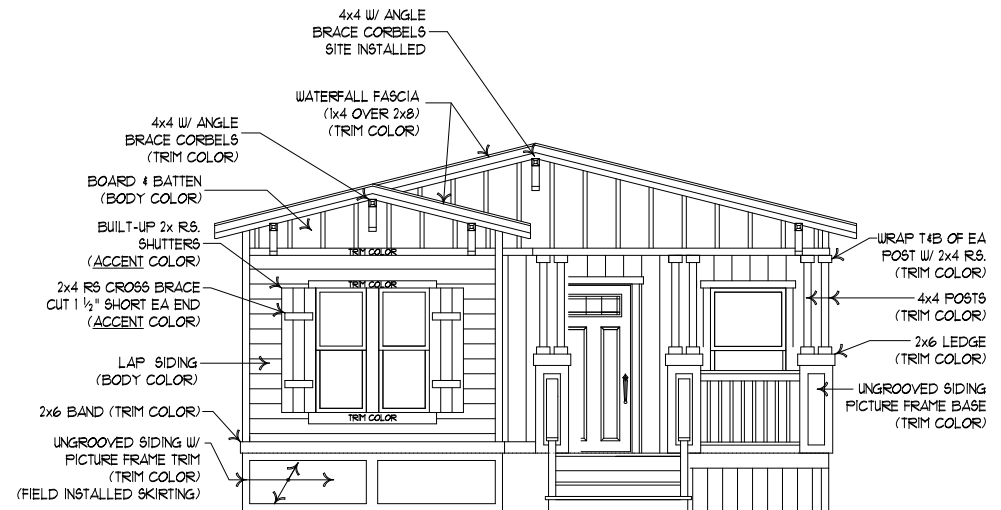

FRONT ENDWALL ELEVATION

CRAFTSMAN EXTERIOR (WITH PORCH)

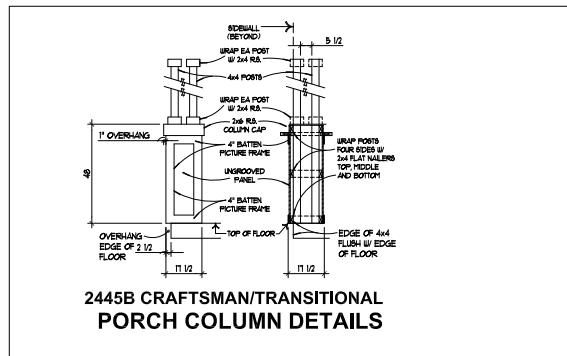

2445B CRAFTSMAN/TRANSITIONAL PORCH COLUMN DETAILS

CMH
MANUFACTURING INC.
9998 OLD PLACERVILLE ROAD
Sacramento, CA. 95827
Phone: (916) 363-2681; Fax: (916) 363-4537
www.claytonhomes.com www.karstenhomes.com

DRAWING TITLE:

EXTERIOR ELEVATIONS

DRAWING FILE INFORMATION:

STANDARD AS OF REVISION DATE

PRODUCT:
CORONADO SERIES

DESIRP.:
24523B

MODEL NO.:
COR24523B

SQUARE FT.:

DATE:
10/04/19

DRAWN BY:

SHEET:
2-A

REVISED:
06-30-23

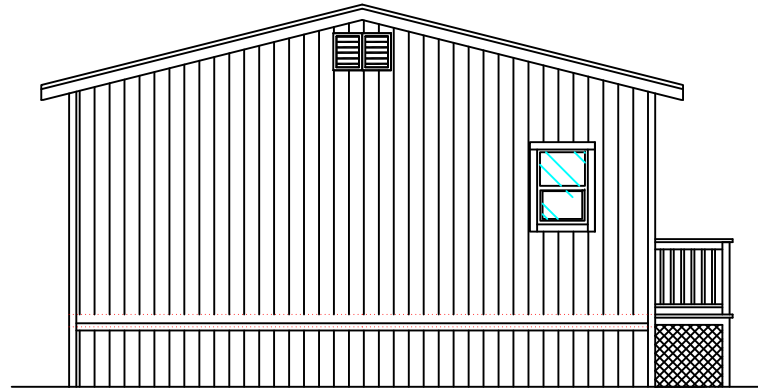

ENDWALL ELEVATION - REAR

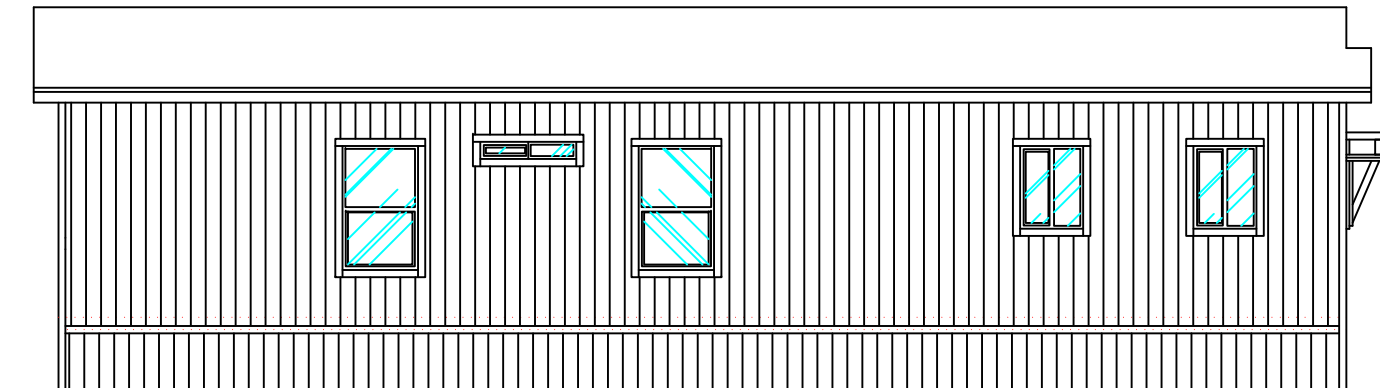

SIDEWALL ELEVATION - LEFT



9998 OLD PLACERVILLE ROAD
 Sacramento, CA. 95827
 Phone: (916) 363-2681; Fax: (916) 363-4537
 www.claytonhomes.com www.karstenhomes.com

DRAWING
 TITLE:

EXTERIOR ELEVATIONS

DRAWING FILE INFORMATION:

STANDARD AS OF REVISION DATE

PRODUCT: CORONADO SERIES	DESRI.P.: 24523B	MODEL NO.: COR24523B
	SQUARE FT.:	DATE: 10/04/19
DRAWN BY:	SHEET: 2-B	REVISED:

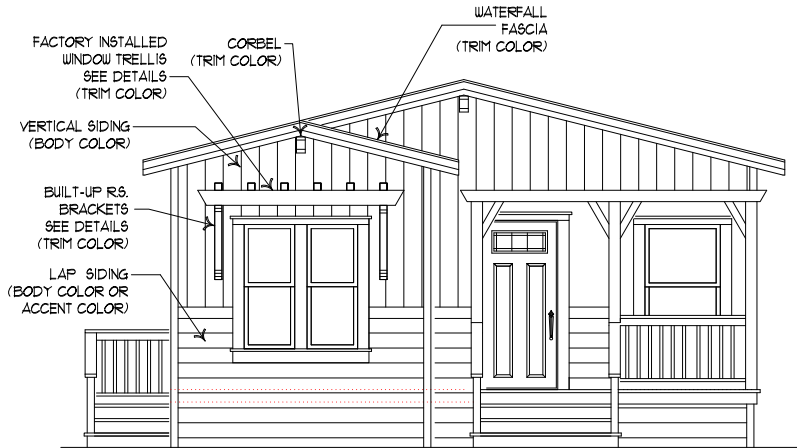

ENDWALL ELEVATION - FRONT (STD)

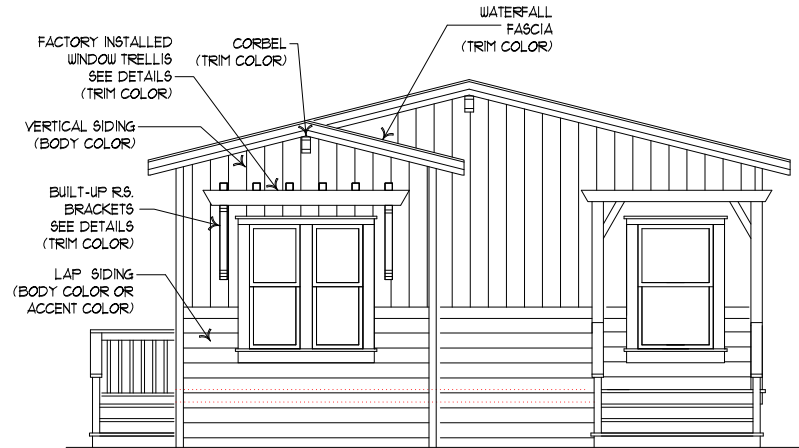

ENDWALL ELEVATION - FRONT (ALT. ENTRY)

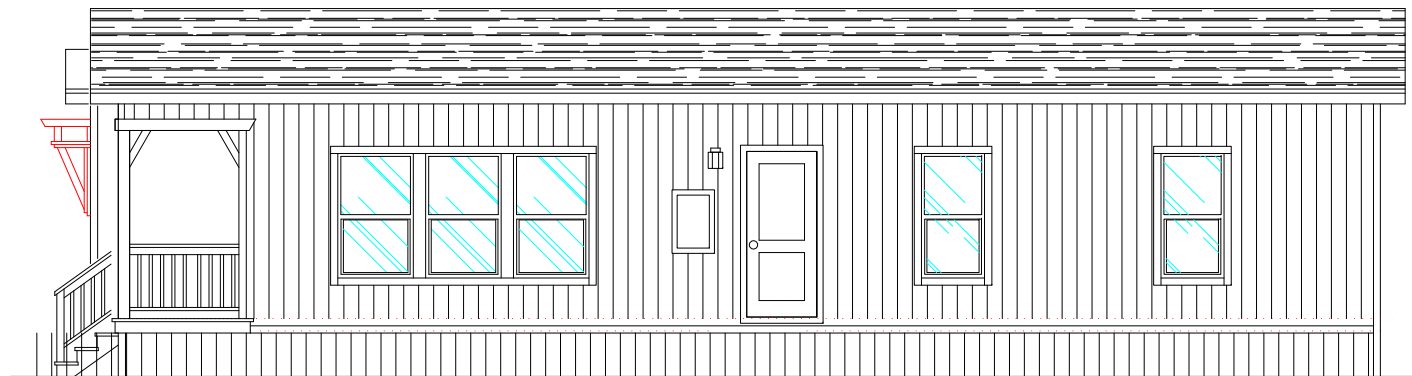

SIDEWALL ELEVATION - RIGHT

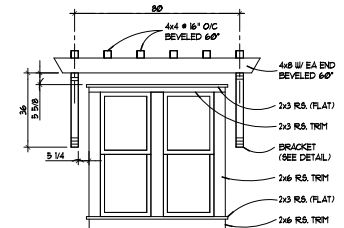

CORONADO TRELLIS WINDOW TRIM DETAIL

TRELLIS EXTERIOR



9998 OLD PLACERVILLE ROAD
 Sacramento, CA. 95827
 Phone: (916) 363-2681; Fax: (916) 363-4537
 www.claytonhomes.com www.karstenhomes.com

DRAWING
 TITLE:

ELEVATIONS - 3

DRAWING FILE INFORMATION:

STANDARD AS OF REVISION DATE

PRODUCT:
 CORONADO SERIES

DESRIP.:
 24523B

MODEL NO.:
 COR24523B

SQUARE FT.:

DATE:
 10/04/19

DRAWN BY:

SHEET:
 2-C

REVISED: